

In-Situ X-Ray Studies of Cocoa Butter Droplets Undergoing Simulated Spray Freezing

M. Pore · H. H. Seah · J. W. H. Glover ·
D. J. Holmes · M. L. Johns · D. I. Wilson ·
G. D. Moggridge

Received: 2 November 2007 / Revised: 15 December 2008 / Accepted: 23 December 2008 / Published online: 24 January 2009
© AOCS 2009

Abstract Spray freezing offers a novel manufacturing route to fine powders with controlled crystalline structures. Here we simulate this process by freezing (using a cold dry air flow) suspended 2-mm diameter droplets of cocoa butter such that X-ray diffraction observation of the droplet's evolving crystalline structure is possible in situ. Initially the Form I polymorph is observed in the droplets: this transforms to Form II over a few minutes and then to Form III over a few hours, even at 0 °C. If the droplet is then warmed to 24 °C, further transformation to Form IV and then Form V occur over approximately 2 h. These phase transformations are similar to those which would be expected in a bulk cocoa butter sample, but occur significantly faster in the droplets. Small crystal sizes in the frozen droplet, resulting from the droplet's low Biot number (and thus even temperature distribution), is postulated as being the cause for the unexpectedly rapid evolution in the crystal habit.

Keywords Cocoa butter · Droplet · Freezing · Microstructure · Polymorphs · X-ray

Introduction

Spray freezing offers a manufacturing route to finely divided powders with new or preferred microstructures as

a result of the higher rate of cooling achievable in drops compared to bulk liquids. There is considerable interest in the food sector in the spray freezing of fats (e.g. Windhab [1]), for controlling microstructure via phase separation, or controlling polymorphic form. For example, van Malssen et al. [2] patented a technique for manufacturing chocolate that replaces the traditional tempering step with an alternative pre-crystallisation process, using Form V seed crystals in the liquid and a feedback technique: the seed powder could be readily generated by spray freezing. Spray freezing is, however, an expensive process on a large scale and it is therefore unlikely to become a potential method for chocolate manufacture; nevertheless the rapid transformation of droplets to Form V could make them a useful source of seeding material in this and other processes.

There have been a number of previous papers describing the effect of thermal history (for example Wille and Lutton 1966 [3]; van Malssen et al. 1999 [4]; Marangoni and McGauley 2003 [5]), shear history (Mazzanti et al. 2004 [6]; Mazzanti et al. 2007 [7]; Sonwai and Mackley 2006 [8]) and triglyceride composition (see for example Foubert et al. 2004 [9]) on the formation of different cocoa butter polymorphs, but there are no previous reports highlighting the effect of thermal gradients within a sample on the rates of phase transformations in cocoa butter.

In a previous paper [10] we reported the use of a novel single droplet freezing apparatus to study the freezing behaviour of droplets of tripalmitin and cocoa butter and mixtures thereof. The apparatus also allows one to generate droplets for microstructure analysis and one of the findings reported from X-ray analysis was that the fats were recovered in their more stable forms, namely β for PPP and Forms V/VI in cocoa butter. We hypothesised that both fats recrystallised rapidly from

M. Pore · H. H. Seah · J. W. H. Glover · D. J. Holmes ·
M. L. Johns · D. I. Wilson · G. D. Moggridge (✉)
Department of Chemical Engineering, New Museums Site,
Pembroke Street, Cambridge CB2 3RA, UK
e-mail: gdm14@cam.ac.uk

D. I. Wilson
e-mail: diw11@cam.ac.uk

initial, less stable forms, over the time required to transfer the droplet from the single droplet freezing apparatus to the X-ray system. This finding is investigated further here by constructing a version of the single droplet freezing apparatus which fitted inside the X-ray system so that drops could be observed in situ over the freezing process.

Experimental Procedures

Materials

Cocoa butter (Gerken's Cacao, BV) was obtained as a solid and used without any additives. DSC profiles of this material were reported in [10]; the onset of a broad solidification peak is observed at 15 °C. Cocoa butter was normally stored in clean vials in an incubator at 80 °C for at least 24 h prior to testing in order to melt any crystallites and avoid any memory effect (e.g. Davis and Dimmick [11] isolated Form V seed crystallites with melting points estimated as high as 72 °C).

Apparatus

A version of the droplet freezing apparatus was constructed to fit within the $2 \times 1 \times 1$ m box chamber of the laboratory's customised Bruker GADDS X-ray diffraction system. Figure 1 shows a schematic of the apparatus. Laboratory compressed air was passed from a regulator equipped with an oil trap through a silica gel dehumidifier and a rotameter (flowmeter) before entering a 1 m long \times 6 mm i.d. coiled copper tube immersed in a refrigerated liquid bath (Cole Palmer) located underneath the chamber. The cold dry exit air then passed through insulated tubing into the base of an upright 20×20 mm square Perspex duct open at the top to atmosphere similar in configuration to the droplet freezing apparatus reported in the previous paper: the principal difference between the devices is the separation of cooling and duct stages. A K-type thermocouple located at the base of the duct monitored the air temperature, T_a . Grooves in the top of the duct supported a mounting for either thin-wire (50 μ m) T-type thermocouples or drawn glass filaments, which located droplets at the centre of the duct 30 mm from the open end. Experiments featured an air flow rate of

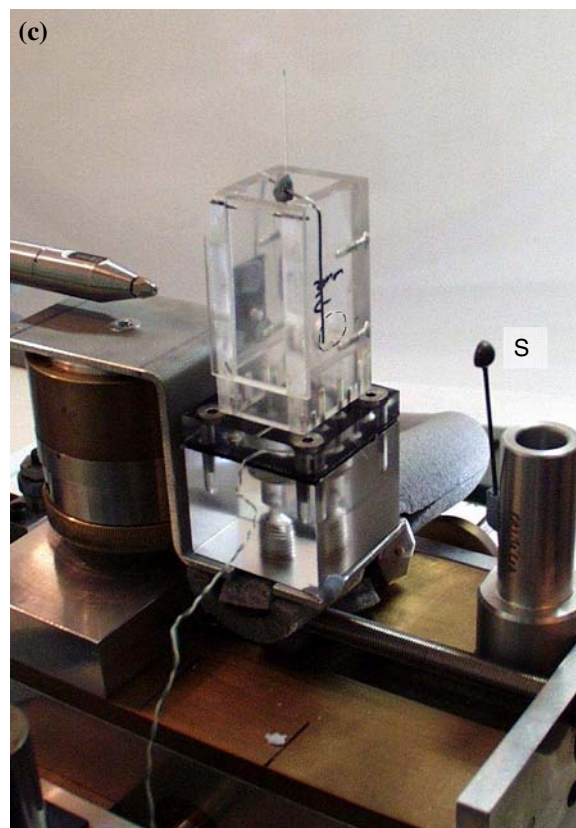
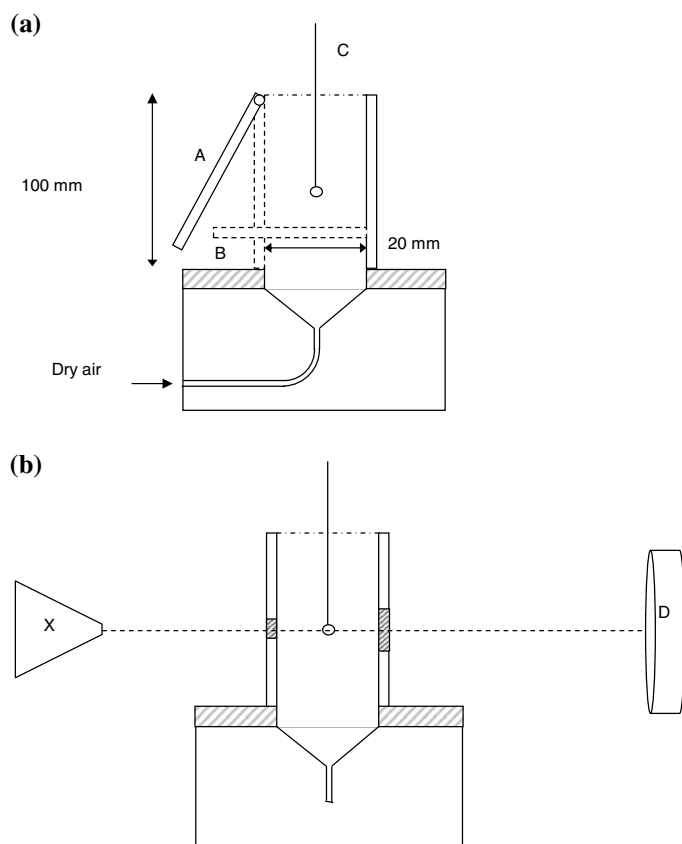

Fig. 1 Schematic of the in-situ X-ray droplet freezing apparatus. **a** side elevation showing loading door *A*, air flow diverter plate *B* in position and suspending filament *C*; **b** side elevation showing X-ray

source *X* and detector *D*, hatched regions on walls indicate portals for X-ray passage; **c** photograph of apparatus. *S* indicates beam stop

$1.2 \text{ m}^3 \text{ h}^{-1}$, corresponding to a superficial velocity in the duct of 0.83 m s^{-1} , and an inlet air temperature of $0 \text{ }^\circ\text{C}$.

Droplets of approximately 2 mm diameter were produced using a 10- μl syringe, which was kept warm at $80 \text{ }^\circ\text{C}$, and suspended on the thermocouple junction or end of the glass filament. In both cases, a thin coating of nail varnish on the end helped the droplet adhere without promoting nucleation [12]. The apparatus was cleaned between runs using warm dodecane to dissolve cocoa butter, and then rinsed with acetone.

X-ray diffraction (XRD) measurements were performed using a Bruker GADDS system employing a Cu K α ($\lambda = 0.1541 \text{ nm}$) source at 45 kV and 45 mA. Calibration using a silver behenate sample accurately located the beam centre and sample distance. The Bruker HISTAR 2D-detector was positioned 0.18 m from the specimen at an angle of 15° off the centre-line giving a 2θ diffraction range of approximately $4\text{--}24^\circ$. Exposures were performed for a maximum of 150 s or 5×10^6 counts.

Method

Cold air was passed through the apparatus to bring its temperature to the required setting before any tests were performed. During droplet loading, the cold air flow was diverted by a gate arrangement and the droplet was positioned on the glass filament using the 10- μl syringe. Closing the gate exposed the droplet to the cold air flow instantaneously and started the cooling and freezing process. The droplet was then quickly aligned in the centre of the duct and the X-ray beam before the first pattern was recorded. This process usually took less than 2 min. The air temperature was monitored continuously and XRD patterns were recorded at fixed intervals after the introduction of the droplet.

The thermal history of the droplet was studied under identical conditions with the capillary replaced by a thermocouple, as reported in [10]. Repeated freezing cycles could be followed by melting the frozen droplet in place using a secondary hot air supply.

There are two nomenclature schemes employed for the cocoa butter polymorphs, as reported by Wille and Lutton [3] and van Malssen [13] and summarised in Table 1. In this paper we use the Form I–VI nomenclature of Wille and Lutton [3].

Figure 2 shows X-ray patterns of Forms I–V cocoa butter, prepared by Sonwai [14] and X-rayed with the same equipment used in this work. Table 2 is a compilation of the principal peaks in the range $15\text{--}25^\circ 2\theta$ for each of Forms I–V and their approximate relative intensities, determined from the Sonwai X-ray patterns. Note that it is believed that the Form IV pattern was contaminated with some Form V, hence the peak around $19^\circ 2\theta$ [not included in Table 2]. Form VI was not observed in any of our

Table 1 Cocoa butter solid polymorphs

Form	Melting points ($^\circ\text{C}$) Wille and Lutton [3]	Phase	Melting range ($^\circ\text{C}$) van Malssen [4]
I	17.3	γ	(-5)– 5
II	23.3	α	$17\text{--}22$
III	25.3	}	β'
IV	27.5		
V	33.8	}	β
VI	36.3		

experiments (not surprisingly, since it usually requires long periods of time to produce). For comparison Table 3 gives the peak positions and approximate strengths reported by Wille and Lutton [3]. The only significant discrepancy with Sonwai's results (and those we report here) is in the minor peak of form I which Sonwai observed at $23.0^\circ 2\theta$, but Wille and Lutton report at $24.0^\circ 2\theta$; we cannot explain this discrepancy, but it does not influence the interpretation of our results.

Figure 2 and Table 2 provide the basis for the identification of the cocoa butter polymorphs present in our experiments. It is fairly straightforward to distinguish Forms IV and V, since their principal peaks occur at distinct angles. However Forms I, II and III all have major peaks in similar positions. Form II can be distinguished by the absence of the smaller peak at around $23^\circ 2\theta$, present in both Forms I and III. Distinguishing Forms I and III would be very difficult on X-ray evidence alone, though it would be possible using the small peak at $19.2^\circ 2\theta$ in Form III. However, in our experiments this was not a problem, since Form I is only ever present before Form II, whilst Form III only occurs after Form II (due to the order of thermodynamic stability). Hence the presence of the $23^\circ 2\theta$ peak prior to the appearance of Form II indicates the presence of Form I, whilst its presence after Form II indicates Form III. Due to the overlapping peaks of the different Forms, it is always possible that there is an impurity of a second Form obscured by the principle Form observed in X-ray diffraction. This is particularly a problem for Forms I–III, where 20% of a secondary form could easily be masked by the principal X-ray pattern (in particular an impurity of Form II in either Form I or III will be very hard to pick up since it has no distinct peak).

Results and Discussion

Temperature

Figure 3 shows temperature profiles recorded in a 2-mm cocoa butter droplet under the freezing conditions

Fig. 2 X-ray diffraction patterns of polymorphs Form I–V of cocoa butter, prepared by appropriate thermal treatment (from Sonwai [14]). Note that it is believed that Form IV is contaminated with a small amount of Form V

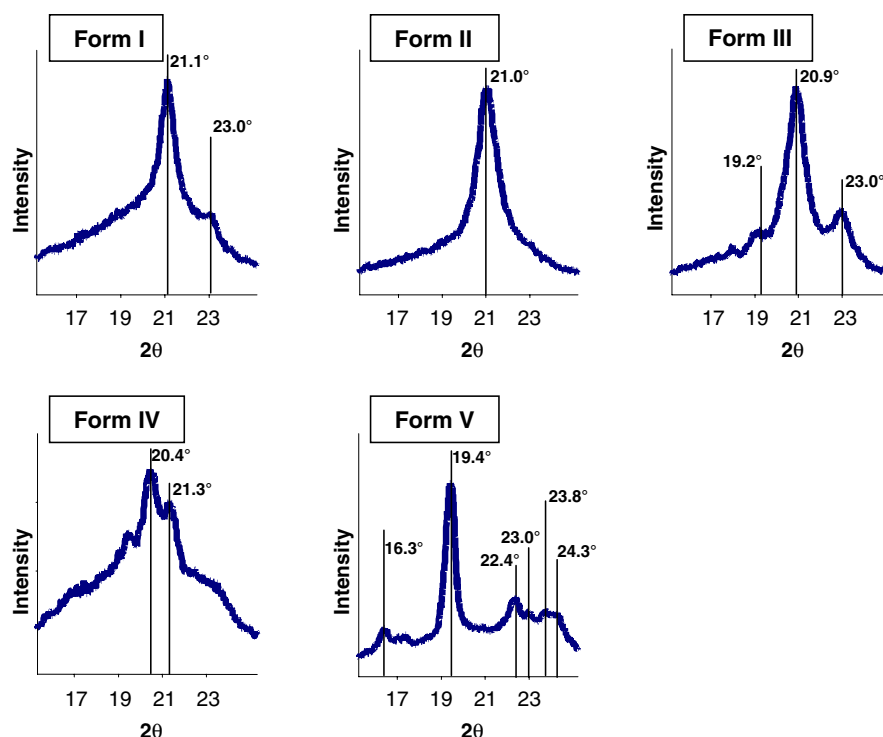

Table 2 Characteristic peaks and intensities (relative to the most intense peak) of cocoa butter polymorphs between 15° and 25° 2θ (measured from patterns from Sonwai [14], Fig. 2)

Form I		Form II		Form III		Form IV		Form V	
2θ	Intensity	2θ	Intensity	2θ	Intensity	2θ	Intensity	2θ	Intensity
Sonwai									
21.1°	100	21.0°	100	19.2°	8	20.4°	100	16.3°	11
23.0°	14			20.9°	100	21.3°	57	19.4°	100
				23.0°	23			22.4°	15
								23.0°	4
								23.8°	6
								24.3°	5

Table 3 Characteristic peaks and approximate intensities (*W* weak, *M* medium, *S* strong, *V* very, *diff* diffuse) of cocoa butter polymorphs between 15° and 25° 2θ (reported by Wille and Lutton [3])

Form I		Form II		Form III		Form IV		Form V	
2θ	Intensity	2θ	Intensity	2θ	Intensity	2θ	Intensity	2θ	Intensity
Wille and Lutton									
21.2°	VS	20.9°	VS	18.0°	VW	20.4°	VS	16.4°	M
24.0°	S			19.2°	W	21.4°	VS	17.2°	W
				20.9°	VS	22.4°	M diff	19.4°	VS
				23.0°	S	23.3°	M diff	21.0°	VVW
								22.3°	S
								23.0°	M
								23.7	M
								24.2	W

employed in the XRD work with an air temperature, $T_a = 0^\circ\text{C}$. The runs show reproducible behaviour, with the onset of freezing marked by a discontinuity in the profile

around 16 s corresponding to a temperature of $\sim 14^\circ\text{C}$. The onset of freezing was observed to lie consistently close to this value. The droplet size results in a small Biot

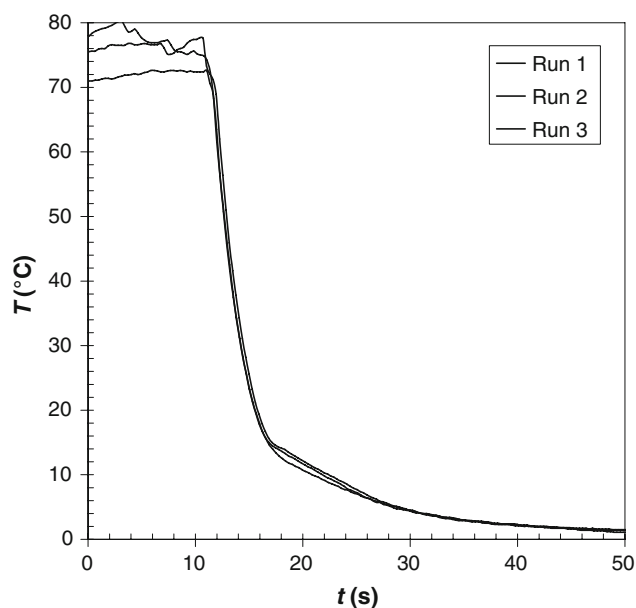

Fig. 3 Temperature profiles of a single cocoa butter droplet frozen at $T_a = 0^\circ\text{C}$ and re-melted to produce three profiles. The droplet temperature was held above 70°C for at least 20 s prior to freezing

number ($Bi = 0.24$) so the temperature in the droplet is close to uniform. The range of initial cooling rates was $12\text{--}17\text{ K s}^{-1}$ and the cooling rate after the onset of solidification was $0.2\text{--}0.8\text{ K s}^{-1}$. Under these conditions (high cooling rate, low air temperature) initial crystallisation would be expected to yield Form I of cocoa butter closely followed by transformation to Form II [4].

Ex-situ XRD

The protocol used to generate droplets reported in [10] was used to benchmark the technique and demonstrate the impact of transfer to the XRD machine. Droplets were frozen in the apparatus reported in [10] on a glass filament and then immediately transported to the X-ray unit in an insulated container chilled by dry ice. The delay time was approximately 5–10 min, given successful alignment. Two ‘batches’ of cocoa butter melt were used, both taken from the same solid sample. Batch A was melted and stored in an incubator at 80°C for 24 h prior to testing, while batch B was melted in a water bath at 80°C approximately 30 min prior to freezing. This was to investigate whether a memory effect might be the cause of any unexpected results, if the duration in the hot bath was insufficient to remove this.

Typical spectra are presented in Fig. 4. Each profile represents a different experiment. The majority of tests yielded spectra as shown in Fig. 4, with a strong peak at $21^\circ 2\theta$ associated with Form II; evidence for Form III can also be seen in some of the patterns in Fig. 4 (see small

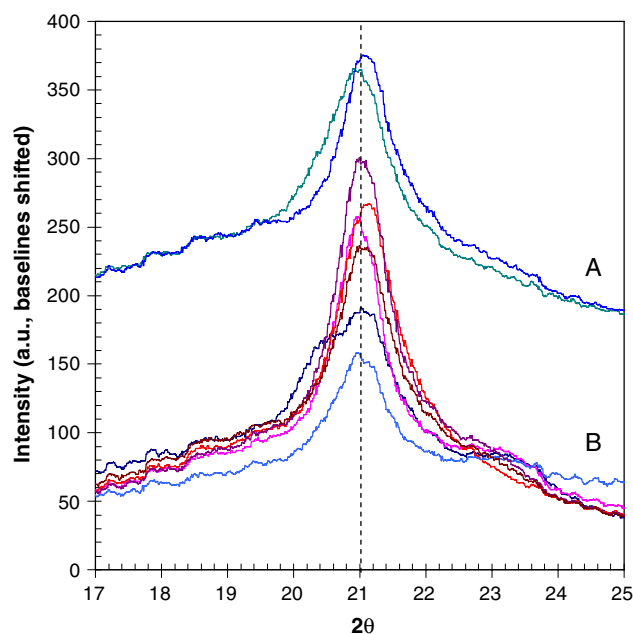

Fig. 4 Typical X-ray diffraction patterns of droplets frozen externally and transported immediately to the XRD system. Batch A cocoa butter stored at 80°C for 24 h prior to use; Batch B cocoa butter melted in a hot bath at 80°C 30 min beforehand. Each profile represents a different test

peak at $23^\circ 2\theta$), consistent with later in-situ results (see Fig. 5). Any Form I formed is likely to be short-lived and transformed to Form II prior to analysis. Occasionally a pattern (not shown) corresponding to a mixture of Forms III and IV was observed. The reason for the more stable Forms III/IV sometimes being observed, rather than the usual Form II (or III), must lie in small differences in transportation, storage and the duration spent in the X-ray system at room temperature (principally the time needed for alignment in the X-ray beam), highlighting the need for in-situ measurement. There was no effect of the two preparation techniques, A and B, on the prevalence of either pattern: batch A preparation was used for all subsequent work.

In-Situ XRD

Figure 5 shows the series of spectra obtained from a cocoa butter droplet frozen in the new apparatus with air at 0°C . (In this and subsequent plots the spectra baselines are shifted for clarity.) Form I is initially observed, but transforms within 10 min to Form II (deduced from the disappearance of the $23.0^\circ 2\theta$ peak); this is as expected for the temperature and cooling rate present in the experiment, though the speed of complete transformation to Form II is perhaps surprising. A further phase transition from Form II to Form III then occurs gradually over several hours (growth of a peak at $23.0^\circ 2\theta$). This is an unexpected result

Fig. 5 XRD patterns of a droplet frozen in situ at 0 °C, and held at this temperature for 20 h. Baselines are shifted for clarity. Transformation from Form I to Form II occurs over 10 min or so, further transformation to Form III takes several hours

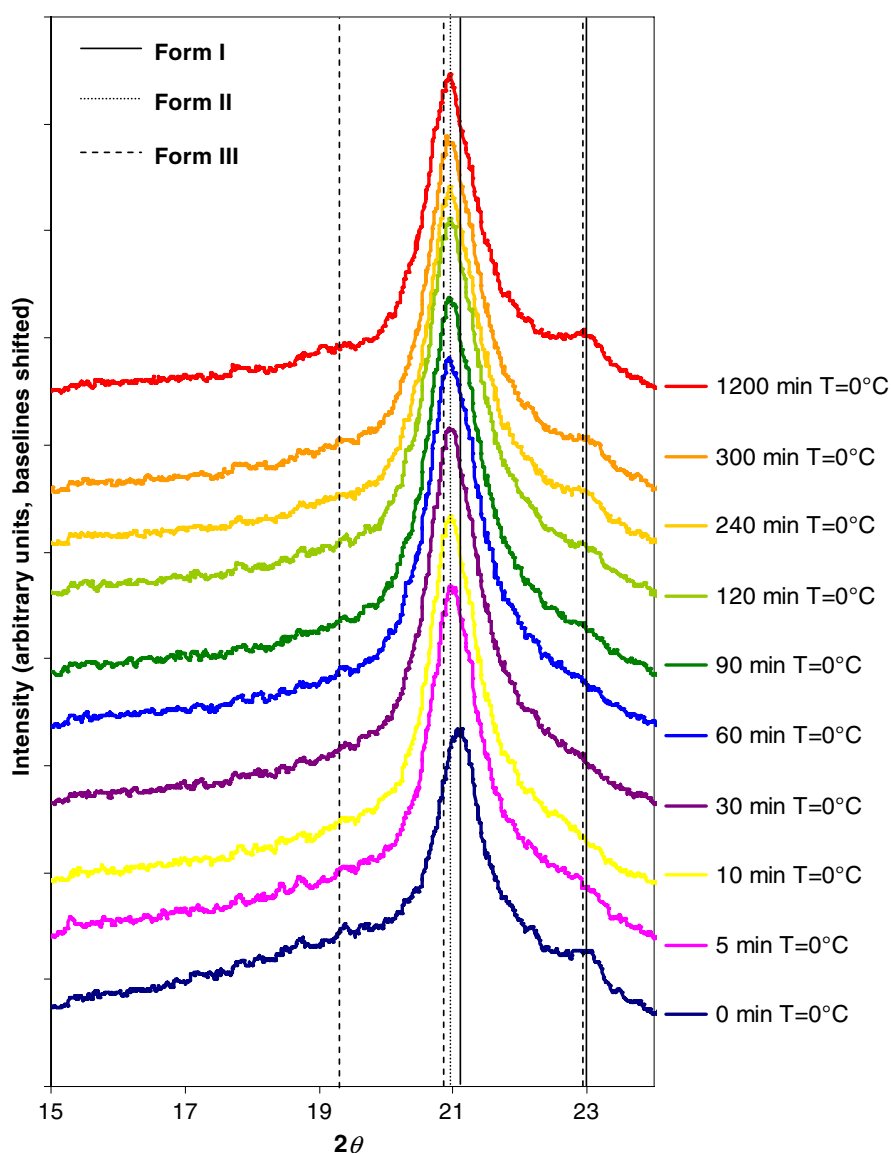

as previous research has suggested that transformation to Form III does not occur, or occurs only very slowly below 5 °C. Wille and Lutton [3] predicted that form II would only just start to transform to form III, at 0 °C, after 5 h whereas here it has been observed over shorter times: van Malssen et al. [4] would not expect transformation to Form III at all at 0 °C.

It is likely that the final pattern observed after 1,200 min is in fact a mixture of Forms II and III. An impurity of Form II in Form III is very hard to detect since the principal peaks are in almost the same place and Form II has no distinct peaks. The relative intensity of the peak at 23.0° 2θ to the main peak at 20.9° 2θ is about 13% after 1,200 min, whereas for the standard pattern of Fig. 2 it was 23%, suggesting the presence of a significant quantity of Form II. No further phase transformation beyond Form III was observed at 0 °C, even over a period of 24 h.

Figure 3 shows that the timescale associated with freezing to be less than a minute whilst Fig. 5 indicates that phase transformation occur over several minutes (Form I to Form II) or hours (Form II to Form III) under freezing conditions. It is clear, therefore, that in practice the powder generated by spray freezing would have to be subsequently stored cold to allow the required phase transformations to take place.

We previously reported the formation of Form V [10], which was not evident in droplets frozen and held at 0 °C in the new apparatus. Droplets frozen at 0 °C (as in Fig. 5) and left to reach room temperature overnight before analysis, however, were found to develop Form V, comparable to the results reported in [10]. This was investigated in the in-situ freezing apparatus by switching the air flow to room temperature (24 °C), after the droplet had frozen and been held at 0 °C for 20 min. The temperature change was

recorded by the thermocouple located in the duct. The characteristic time for a frozen droplet to respond to a step change in ambient temperature is of the order of 2–4 s if sensible heat changes alone are involved, so this thermocouple gave a reasonable estimate of the droplet temperature.

The results are shown in Fig. 6. Initially Form I is formed and, by 20 min, has transformed to Form II, with a hint of the presence of some Form III. This result is consistent with the experiment shown in Fig. 5 (the conditions in the two experiments should be identical up to 20 min). At 40 min, 20 min after the air flow is switched to 24 °C, a considerable amount of melting is evident (liquid cocoa

butter has a very broad peak around 19° 2 θ [14]), and Form IV has started to appear. The melting point of Form II is reported by Wille and Lutton [3] to be 23.3 °C and by van Malsen [4] in the range 17–22 °C; the same authors report the melting point of Form III to be 25.3 °C and 20–27 °C. The most likely explanation for this behaviour is therefore that the less thermodynamically stable phases (II and III) are melting and then recrystallising on pre-existing nuclei of more stable phases, principally Form IV (which has a melting point above 24°, though it is possible that a small amount of Form V is also present even at this stage (see peak at 19.4° 2 θ). From 40 to 90 min, the amount of Form IV increases, but Form V increases at a faster rate. Beyond

Fig. 6 XRD spectra of a cocoa butter droplet frozen and held at 0 °C for 20 min, then warmed to 24 °C and held at this temperature. Baselines are shifted for clarity. Transformation to Forms IV and then V occurs

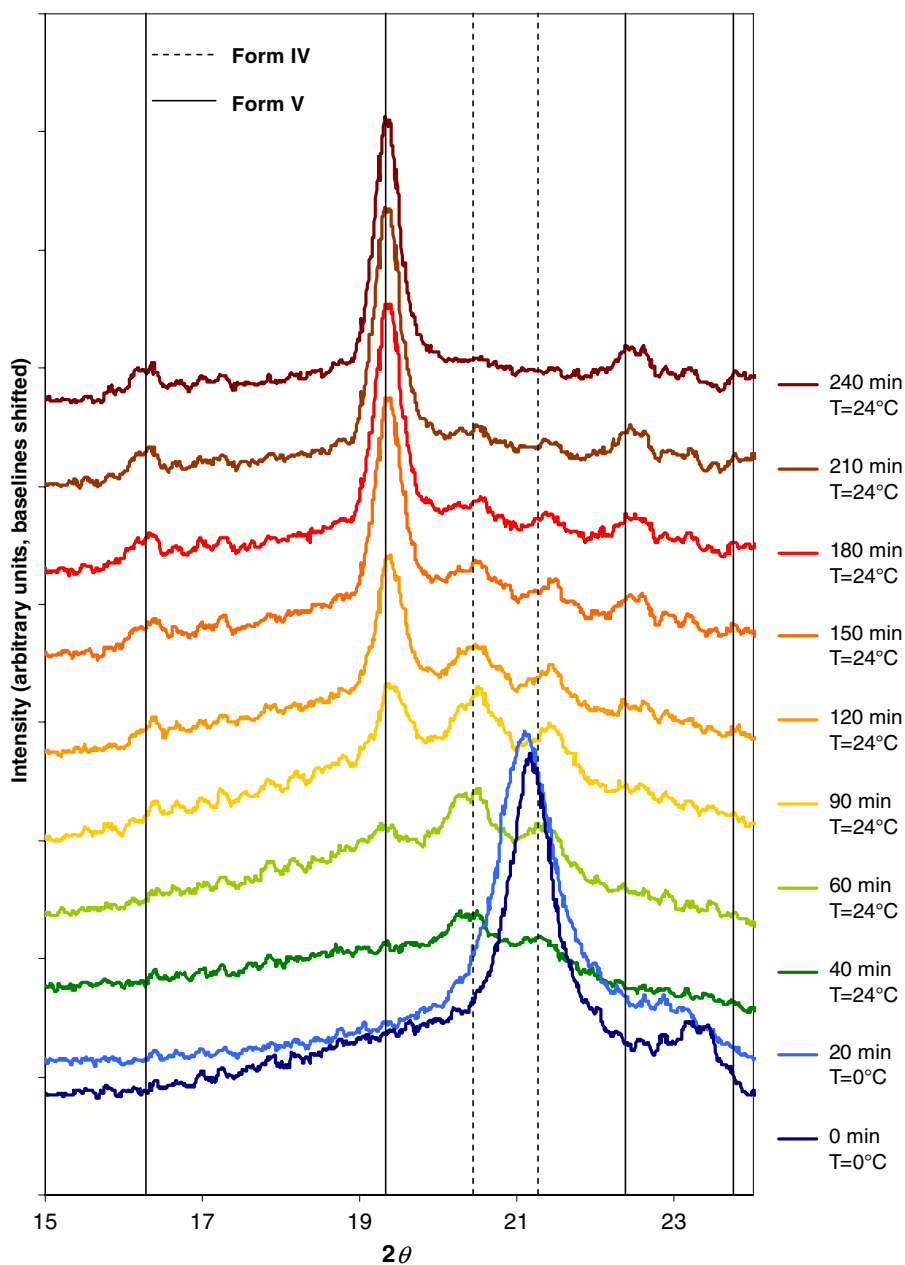

90 min Form IV starts to decline, as Form V continues to increase, until the transformation to Form V is complete by about 240 min. The transformation from Form IV to Form V may be a direct solid-solid transformation or may occur via a co-existing liquid phase, in a process akin to Ostwald ripening. The formation of Form V over such a short timescale is another surprising result: reports in the literature suggest that in bulk systems this transformation is difficult to achieve (hence the need for tempering in industrial manufacture of chocolate, where Form V is the desired product) and takes much longer to complete, usually of the order of 24 h [3–5, 13, 14]. Van Malssen [4] reports that Form V always takes longer than 12 h to form and at 24 °C 3 days or more; Marangoni and McGauley [5] suggest that more than 1,000 h are required for Form V formation, even at 25 °C.

Figure 7 illustrates the evolution of each phase over time. The integrated intensity of the principal peak for each Form of cocoa butter present is plotted over time. It should be noted that the principal peaks of Forms I, II, and III occur in almost the same place. It is therefore possible that peaks assigned to one of these phases in fact contain a significant amount of impurity of another of these three phases. The intensity is proportional to the amount of

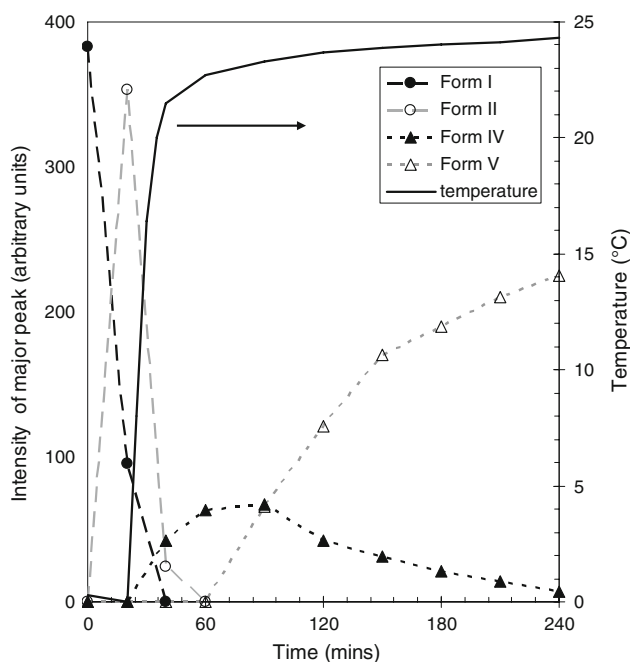

Fig. 7 Development of polymorphs in Fig. 6. Intensity of the major peak of each polymorph present is plotted as a function of time, on the left axis. The temperature is plotted on the right axis. Tie lines have been added as a guide to the eye. (Note that although the units used for the peak intensity are arbitrary, they are the same for all polymorphs, and the same as for Fig. 9, thus the same intensity in the left axis for the same polymorph in principle represents the same amount of material in both Figs. 7 and 9)

crystal present for each Form (assuming there are no anisotropic alignment effects occurring, which is very unlikely in a spherical drop system), so this plot should accurately reflect the change in extent of each phase individually. However, the intensity is not comparable between different phases—there is no reason to assume that the principal X-ray diffraction peaks of pure crystalline samples of different polymorphs would have the same intensity. We cannot use our standard X-ray patterns for the different polymorphs (Fig. 2) to normalise this, because there is an unknown amount of liquid cocoa butter present in each case (it is clear from the broad backgrounds that liquid cocoa butter is present in at least some of the standard samples). It is very difficult (probably impossible) to prepare pure, liquid free standard samples of the different crystal forms of cocoa butter. Figure 7 also shows the temperature as a function of time.

Figure 8 shows a similar experiment to that of Fig. 6, but with the initial freezing carried out at 10 °C (rather than 0 °C); the temperature was held at 10 °C for 20 min, prior to switching the air flow to 24 °C as previously. Figure 9 shows the evolution of polymorphs and temperature (again it should be remembered that minority phases of Forms I, II or III in another of these three phases will be hard to distinguish). The general behaviour is similar to that seen in Fig. 6, with Form I initially forming and transforming to Form II at the freezing temperature; followed by the formation of Form IV and then Form V once the temperature is raised to 24 °C after 20 min. However there are important differences of detail. As one would expect the initial freezing is slower and less complete at 10 °C than at 0 °C; more surprisingly the transformation from Form I to Form II is slower at 10 °C and the transformation to Form III is not observed at all within 20 min. The phase transformations after the increase of temperature at 20 min are also slower and less complete than was the case for freezing at 0 °C (Figs. 6, 7). There seems to be a significant liquid cocoa butter fraction present throughout the experiment, and there is still a significant quantity of Form IV remaining even after 360 min. This is an interesting result, as it is clear that the rate of subsequent phase transitions is strongly dependent on the initial freezing conditions (even though the majority of the crystals formed during this freezing stage melt prior to these transformations occurring). All phase transitions seem to be slower if the initial freezing temperature was higher.

We draw two significant conclusions from this work. The first is that freezing cocoa butter in small droplets with a low Biot number (analogous to the spray freezing process) results in phase transformations between the different polymorphic forms occurring much faster than they would be expected to do in bulk samples. This is true both for the low temperature transition from Form I to Form II and then

Fig. 8 XRD spectra of a cocoa butter droplet frozen and held at 10 °C for 20 min, then warmed to 24 °C and held at this temperature. Baselines are shifted for clarity. The same transformations are observed as in Fig. 6, but they occur more slowly and less completely. (Note that for convenience of plotting the intensity scale is not the same as that used in Fig. 6)

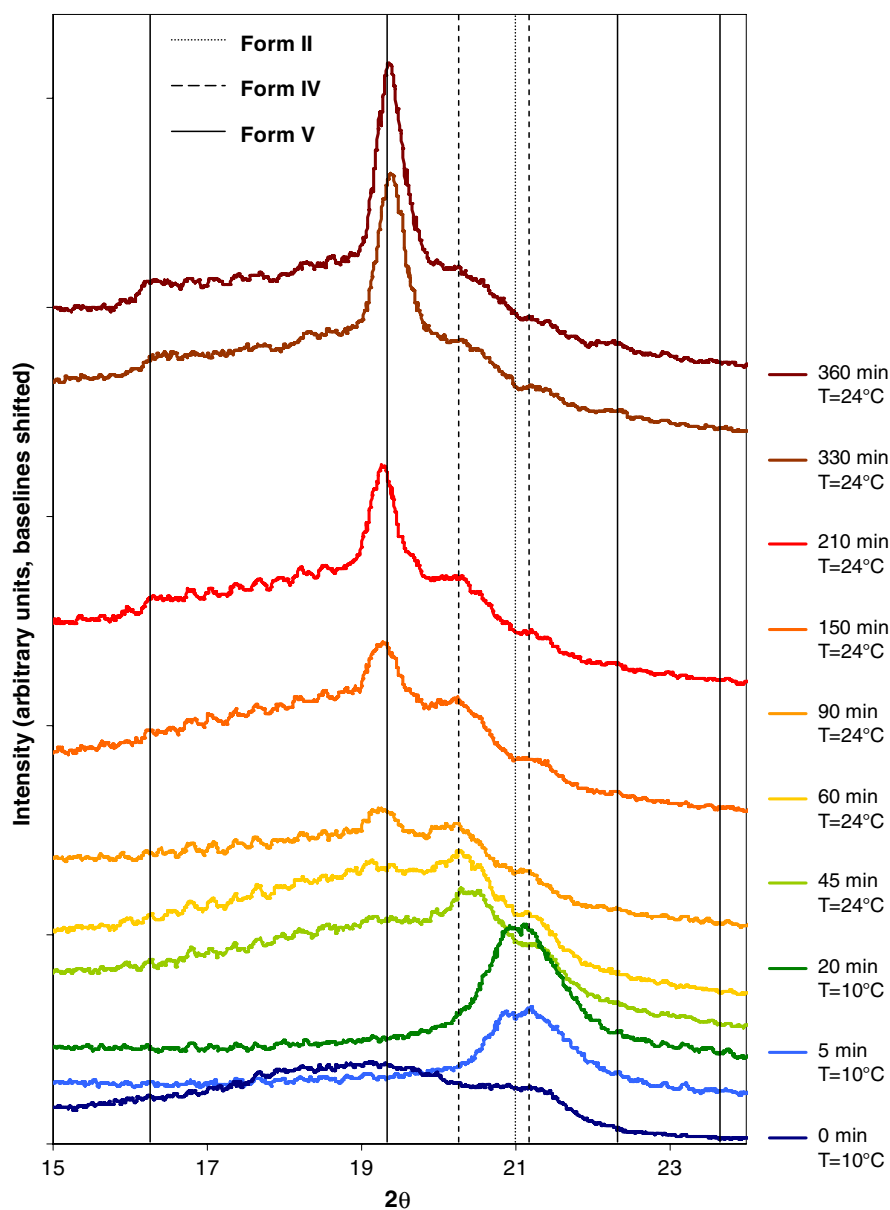

to Form III, and also the subsequent transitions at higher temperature to Form IV and Form V; of most potential practical significance is the much faster transition to the desirable Form V which can be achieved. The second is that these phase transitions occur more slowly if the initial freezing temperature is higher (10 °C rather than 0 °C); this is the case both for the low temperature transitions (Form I to Form II to Form III) occurring at either 0 °C or 10 °C, and the subsequent transformation to Forms IV and V, when the temperature (24 °C) is the same in both experiments. This reinforces the conclusion that there is a “memory” of previous thermal processing (in this case the freezing temperature) retained in the droplet even after it has been raised to a higher temperature.

A plausible hypothesis to explain both these observations is as follows. The low Biot number of the droplet means that the principal thermal gradient is that outside the droplet and that all the cocoa butter within the droplet will be at almost the same temperature. This is in contrast to the case of a bulk sample undergoing freezing, where significant thermal gradients are to be expected within the sample. If the temperature is almost constant throughout the sample, it follows that nucleation will occur almost simultaneously at all points, and therefore a large number of small crystals are expected to be formed. By contrast, in a bulk sample nucleation will occur first at the coolest points and then crystallisation is more likely to proceed via growth from the cooler to the warmer regions; hence in this

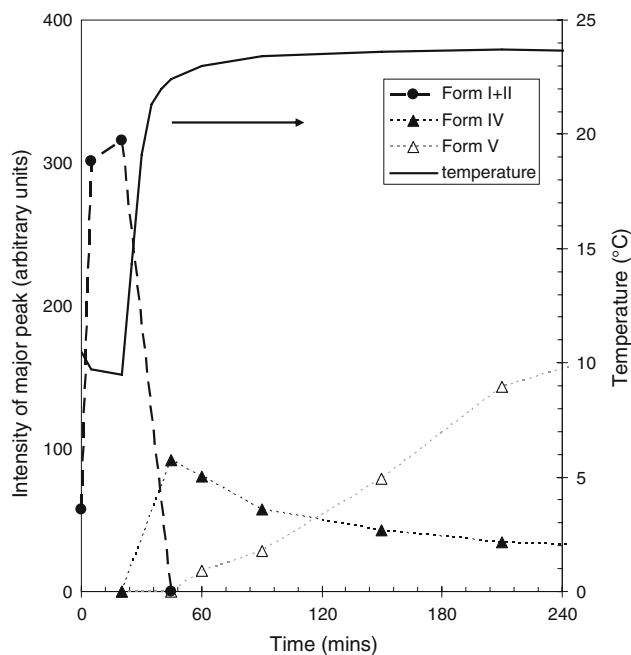

Fig. 9 Development of polymorphs in Fig. 8. The intensity of the major peak of each polymorph present is plotted as a function of time, on the left axis. The temperature is plotted on the right axis. *Tie lines* have been added as a guide to the eye. (Note that although the units used for the peak intensity are arbitrary, they are the same for all polymorphs, and the same as for Fig. 7: thus the same intensity in the left axis for the same polymorph in principle represents the same amount of material in both Figs. 7 and 9)

case we expect a smaller number of larger crystals. This is consistent with the well known observation that higher degrees of subcooling result in smaller crystals, as nucleation occurs more evenly throughout the sample.

Let us hypothesise that during nucleation at a particular temperature, a given fraction of nuclei form spontaneously in each polymorphic form and that there is an inverse relationship between thermodynamic stability (increasing from Form I to VI) and kinetic ease of formation. Thus at 0 °C we expect most nuclei to be Form I, but a smaller number to be successively more stable polymorphs, including even Form V. If a larger number of smaller crystals form (low Biot number case), all other things being equal, a larger number of nuclei of higher Forms, including Form V will result. When the temperature is raised above the melting point of the lower forms, these nuclei act as propagation centers for the growth of the thermodynamically more stable forms. The more such nuclei exist, the faster will be the growth rate per unit volume of cocoa butter, and so the faster the phase transformation. This mechanism assumes transformation from one solid phase to another, via an intermediate liquid phase, growth occurring on existing crystals of the higher crystal phase.

If freezing is carried out at a higher temperature in the first place (e.g. 10 °C rather than 0 °C), the degree of

supercooling in the droplet is smaller and so the rate of nucleation is relatively lower when compared to the rate of growth. Hence there are expected to be fewer, but larger, crystals than in the lower freezing temperature case. This in turn results in there being a smaller number of nuclei of the higher crystal Forms per unit volume and so, when the temperature is raised, the rate of phase transformation to these Forms is correspondingly lower.

An obvious test of the above is to measure the crystal size of the cocoa butter formed under the different conditions and see whether it fits the hypothesis. One problem with this is that growth may be via secondary nucleation on the surface of existing crystals rather than by simple crystal growth. The mechanism proposed above may not therefore in fact result in a large, or even any, difference of crystal sizes. Nonetheless, it seems worth attempting some estimate of the crystal sizes: at the very least, in the case where freezing of a low Biot number droplet results in anomalously high rates of phase transformation, we should observe small crystals in the initially frozen droplets.

Scherrer Analysis

Crystal size (in a direction perpendicular to the scattering planes) can be estimated using Scherrer analysis [15], which relies on the fact that smaller crystals give broader diffraction peaks [16]. Scherrer analysis is at best an approximate method: it assumes monodisperse crystals, requires a background subtraction and subtraction of the instrument's natural line broadening. Diffraction peaks from large crystals of CaO and MgO were used to give an estimate of the equipment's natural line broadening in the region of the relevant angles ($\Delta 2\theta \approx 0.35^\circ$). Scherrer analysis is reasonably accurate for estimating sizes of crystals below a few tens of nanometers (although even then the absolute values should be treated with skepticism), but becomes increasingly inaccurate for larger crystals as the peak width becomes dominated by the instrument's natural line broadening.

The greatest problem for the current data is that non-overlapping peaks are required for a good Scherrer analysis—it is sometimes possible to deconvolute overlapping peaks, but in this work the combined problems of background subtraction and deconvolution were felt to make the treatment of overlapping peaks excessively inaccurate. Unfortunately this is a particular problem at the point when we would particularly like to estimate crystal size, just after freezing—because Forms I, II and III all have overlapping principal peaks around $21^\circ 2\theta$. The only points where we feel reasonably confident of having fairly pure polymorphs, and therefore being able to sensibly perform Scherrer analysis, are after about 30 min in Fig. 5 (where almost pure Form II is present), and at the end of the experiments

in Figs. 6 and 8 (where close to pure Form V exists). The FWHM of the peaks in these three cases are estimated to be $1.01^\circ 2\theta$, $0.38^\circ 2\theta$ and $0.37^\circ 2\theta$, giving estimates of crystal size of 9, 57 and 70 nm respectively.

The peak widths of the Form V crystals in Figs. 6 and 8 are not much greater than the natural line broadening, so there is not much information here beyond the fact that the crystals are “large” (greater than a few tens of nanometers at least) and that the crystals may be somewhat larger in the case where the freezing was carried out at 10°C than at 0°C . This is consistent with the proposed hypothesis—there are expected to be very few Form V nuclei present at freezing and so a relatively large average crystal size should result, if these are principal sites for crystal growth. The approximately 9 nm crystals of Form II in Fig. 5 are small, particularly when one considers the molecular dimensions (see the molecular model suggested by Schenk and Peschar [17]) of cocoa butter. This cannot represent more than a few tens of layers of molecules. Again this is entirely consistent with (although not proof of) the proposed hypothesis, which requires the formation of a large number of small crystals in the rapid freezing of a low Biot number droplet.

Although not conclusive, the Scherrer analysis we have been able to perform gives tentative support for the proposed explanation of our observations. In this connection, it would be interesting to look at the X-ray scattering from other crystal planes in the cocoa butter, both because growth may not be isotropic and because it may be possible to find non-overlapping peaks for the different Forms. In particular a Scherrer analysis of the small angle peaks could be revealing, giving information on the crystal size in the long unit cell dimension, and corresponding to the long direction of the cocoa butter molecules.

Conclusions

We describe equipment for simulating, in situ (whilst acquiring X-ray diffraction data), spray freezing. This will have application beyond the study of cocoa butter described. For example, we have begun to study the freezing of non-ionic liquids in this apparatus.

We have shown that phase transformations of cocoa butter in small frozen droplets (featuring a small Biot number) occur much faster than the equivalent transformations would be expected in bulk samples. In particular, it is possible to achieve Form V (the desirable form for chocolate) much faster in small droplets: this may have practical implications for chocolate manufacturers. Droplets frozen at a lower temperature result in more rapid subsequent phase transformations, even after heating to a constant higher temperature. There is clearly a “memory”

of the freezing conditions retained in the droplet, which affects the subsequent rate of phase transformation. We hypothesise that these observations are due to a high density of nucleation in a small droplet, due to the even temperature distribution within the droplet; this results in a relatively high density of nuclei for the formation of thermodynamically more stable phases as the droplet is warmed and the less stable phases melt.

Acknowledgments Assistance with construction of the apparatus from Joe Nunes and Surinder Sall is gratefully acknowledged. The GADDS system was funded by the EPSRC.

References

1. Windhab E (1999) New developments in crystallization processing. *J Therm Anal Calorim* 57:171–180
2. Van Malssen KF, van Langevelde AJ, Peschar R, Schenk H (2001) Method for the manufacturing of chocolate. European Patent Application EP1204330 (1999)
3. Wille RL, Lutton ES (1966) Polymorphism of cocoa butter. *J Am Oil Chem Soc* 43:491–496
4. Van Malssen K, van Langevelde A, Peschar R, Schenk H (1999) Phase behaviour and extended phase scheme of static cocoa butter investigated with real-time X-ray powder diffraction. *J Am Oil Chem Soc* 76(6):669–676
5. Marangoni AG, McGauley SE (2003) Relationship between crystallization behavior and structure in cocoa butter. *Cryst Growth Des* 3(1):95–108
6. Mazzanti G, Guthrie SE, Sirota EB, Marangoni AG, Idziak SHJ (2004) Novel shear induced phases in cocoa butter. *Cryst Growth Des* 4(3):409–411
7. Mazzanti G, Guthrie SE, Marangoni AG, Idziak SHJ (2004) A conceptual model for shear induced phase behaviour in crystallizing cocoa butter. *Cryst Growth Des* 7(7):1230–1241
8. Sonwai S, Mackley MR (2006) The effect of shear on the crystallization of cocoa butter. *J Am Oil Chem Soc* 83(7):583–596
9. Foubert I, Vanrolleghem P, Thas O, Dewettinck K (2004) The influence of chemical composition on isothermal cocoa butter crystallization. *J Food Sci* 69:E478–E487
10. Gwie CG, Griffiths RJ, Cooney DJ, Johns ML, Wilson DI (2006) Microstructures formed by spray freezing of food fats. *J Am Oil Chem Soc* 83:1053–1062
11. Davis TR, Dimick PS (1989) Isolation and thermal characterization of high-melting seed crystals formed during cocoa butter solidification. *J Am Oil Chem Soc* 66:1488–1493
12. MacLeod CS, McKittrick JA, Hindmarsh JP, Johns ML, Wilson DI (2005) Fundamentals of spray freezing of instant coffee. *J Food Eng* 7:451–461
13. Van Malssen KF (1994) Real time X-ray powder diffraction applied to cocoa butter and graphite intercalates. Ph.D. dissertation, University of Amsterdam
14. Sonwai S (2003) The Effect of Shear on the Crystallisation of Cocoa Butter, Ph.D. dissertation, University of Cambridge
15. Cullity BD (1978) Elements of X-ray diffraction. Addison-Wesley, Mass
16. Mazzanti G, SE Marangoni, AG Idziak, HJ S (2005) Modeling phase transitions during the crystallization of a multicomponent fat under shear. *J Phys Rev E* 71:1230–1241
17. Schenk H, Peschar R (2004) Understanding the structure of chocolate. *Radiat Phys Chem* 71:829–835